



***knight***<sup>®</sup>

**OPERATOR'S MANUAL**

**KG-625 6" VTVM**

## SPECIFICATIONS

|                            |  |
|----------------------------|--|
| <b>INPUT IMPEDANCE:</b>    | 11 megohms on DC   |
| <b>ACCURACY:</b>           | DC — $\pm 3\%$ of full scale<br>AC — $\pm 5\%$ of full scale   |
| <b>DC RANGES:</b>          | 0-0.5-1.5-5-15-50-150-500-1500 volts full scale<br>(to 25,000 volts with accessory high voltage probe)                           |
| <b>AC RANGES:</b>          | RMS — 0-1.5-5-15-50-150-500-1500 volts full scale<br>P-P — 0-4.2-14-42-140-420-1400-4000 volts full scale                        |
| <b>FREQUENCY RESPONSE:</b> | $\pm 1$ db, 30 cps to 3 mc<br>$\pm 3$ db, 30 cps to 5 mc<br>(to 250 mc with accessory high frequency probe)                      |
| <b>OHMMETER RANGES:</b>    | 0-1000-10,000-100,000 ohms<br>0-1-10-100-1000 megohms<br>Center scale — 10, 100, 1000, 10,000, 100,000 ohms and 1 and 10 megohms |
| <b>BATTERY:</b>            | 1½ volt, "C" size  |
| <b>TUBES:</b>              | 12AU7A pre-aged, matched dual triode meter bridge<br>6AL5 full-wave rectifier  |

## TABLE OF CONTENTS

|                                      | Page            |
|--------------------------------------|-----------------|
| <b>GENERAL DESCRIPTION OF KG-625</b> | 1               |
| <b>CONTROL FUNCTIONS</b>             | 2               |
| <b>USING YOUR VTVM</b>               |                 |
| Safe practices                       | 3               |
| Reading the meter                    | 3-5             |
| <b>OPERATING INSTRUCTIONS</b>        | 5-7             |
| <b>SPECIAL APPLICATIONS</b>          | 7-9             |
| <b>MAINTENANCE</b>                   |                 |
| <b>CALIBRATION</b>                   | 10-12           |
| <b>TROUBLESHOOTING</b>               | 12-13           |
| <b>CIRCUIT DESCRIPTION</b>           | 14              |
| <b>SCHEMATIC DIAGRAM</b>             | 15              |
| <b>WARRANTY</b>                      | 16              |
| <b>REPLACEMENT PARTS LIST</b>        | .Separate Sheet |

# MODEL KG-625 DELUXE 6-INCH ELECTRONIC VTVM

*for accurate, entirely electronic, direct-reading  
measurement of AC, DC and ohms*

- Highly Sensitive 0.5 Volt DC Full Scale Range for Transistor Service Work
- Separately Calibrated Scales for 1.5 and 5 Volt RMS, 4.2 and 14-Volt P-P AC
- Gimbal Mount Assures Maximum Mounting Ease and Proper Viewing Angle

The large, 6" style meter movement has a fluorescent, knife-edge pointer, and a 2-color scale. 100° meter arc allows easy viewing from any angle. As a special feature, the movement is shorted out in the "Off" position on the function switch. This prevents accidental damage while carrying instrument. Precision 1% film-type resistors are used as multipliers for highest accuracy. 11 megohm input impedance on DC reduces circuit loading and assures true readings. Swivel stand assures mounting ease in any position — helps make scales more readable. A power transformer is used for line isolation and maximum efficiency.

The precision Model KG-625 VTVM stands unequalled in both performance and value. All the skill and know-how that over 40 years of research and development can provide are incorporated in this superb unit. Components of the finest quality produce the type of VTVM demanded by the technician, serviceman, and electronics enthusiast.

# CONTROL FUNCTIONS

## FUNCTION SWITCH S-1

This switch turns the power ON and selects the desired function.

**OFF** The OFF position disconnects AC power from the unit. In this position, the meter terminals are connected together. This short circuit damps the meter (keeps the needle from swinging freely), so that the instrument can be transported without causing damage to the sensitive meter movement. Always place this switch in the OFF position when you transport the instrument.

**AC (RMS and P-P)** — for AC voltage measurements.

**—DC VOLTS** — for negative DC voltage measurements.

**+DC VOLTS** — for positive DC voltage measurements.

**OHMS** — for resistance measurements.

## SERVICE CONTROLS

The four service controls are accessible through holes in the left side of the cabinet. The controls are used for calibration.

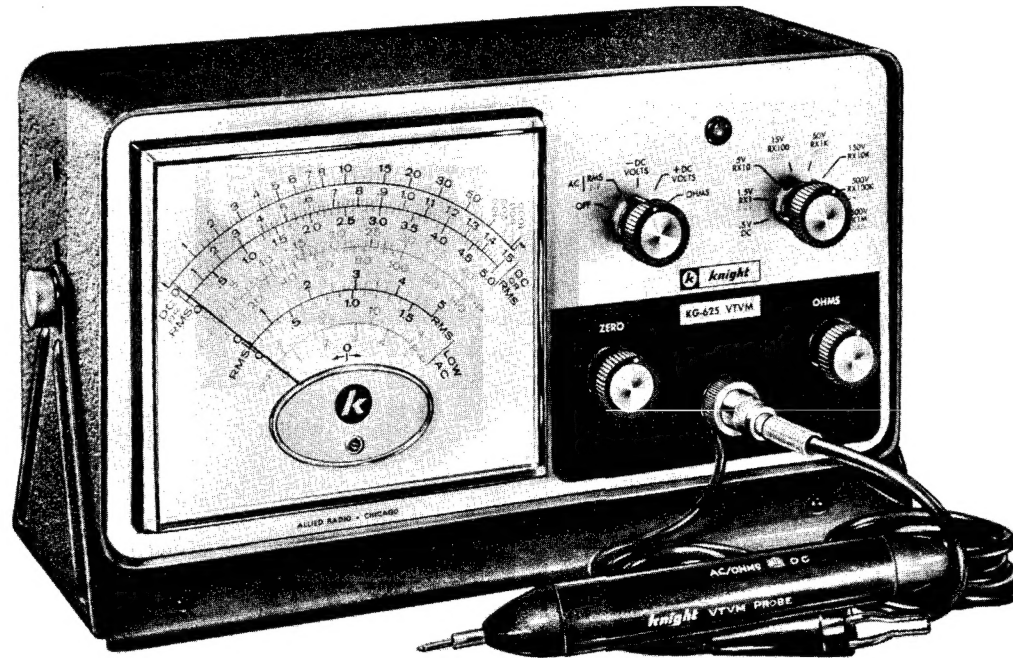

## AC/OHMS — DC PROBE SWITCH

This switch is used to insert a 1 megohm resistor in series with the input for DC measurements. For AC and OHMS measurements, the resistor is removed from the input circuit.

## RANGE SWITCH S-2

This switch selects the full-scale range of voltage or resistance marked on the meter. The first position, .5V DC, is for DC voltage measurements only. The lowest full-scale AC range is 1.5 volts RMS or 4 volts P-P. Markings in red are for P-P voltage measurements.

## OHMS CONTROL

This control is used to set the meter needle to full-scale before resistance measurements are made. It is switched into the plate circuit of the dual triode tube when the FUNCTION SWITCH is in OHMS position. It controls the current flowing through the meter.

## ZERO CONTROL

This control is used to set the meter needle to zero at the left hand side of the scale. The ZERO control is in the plate circuit of the dual-triode in the bridge circuit. It controls the voltage on the plates of the tube and is used to balance the circuit so

the meter needle rests on zero when a measurement is not being taken. This control is also used to set the needle for zero center readings.

# MAINTENANCE

## CALIBRATION

The calibration controls are located at the left side of your VTVM and are accessible through the holes provided in the side of the cabinet. The instrument must be removed from the swivel stand to permit you to use these holes.

You should recheck the calibration of the instrument if you find it necessary to replace any parts, especially if you replace a tube.

**NOTE:** Keep in mind that the accuracy of your VTVM depends on the accuracy of the standard used. Thus if greatest accuracy is desired, use an external standard of known accuracy for calibration.

For DC calibration, a mercury cell battery provides an extremely accurate voltage. Under no current drain conditions, the voltage is 1.354 volts. We suggest this as a readily available, accurate calibration source.

### MECHANICAL ZERO ADJUSTMENT

Check the mechanical zero adjustment of the meter before you make any calibration adjustments.

Disconnect the VTVM line cord from the AC power outlet. With a non-metallic screwdriver, adjust the plastic screw in the lower center of the meter face to bring the meter needle exactly to zero, at the left side of the scale.

Plug the line cord into an AC power outlet and allow the VTVM to warm up for 2 hours before proceeding.

### CAUTION

Do not use the VTVM on a grounded metal bench, radiator or other grounded object. During part of the calibration procedure the instrument will be out of the case; the 120 volt power line voltage and internal voltages will be exposed at this time. Never touch any of the exposed wiring while the instrument is plugged in.

### ZERO ADJUST

- Set FUNCTION SWITCH to +DC VOLTS.
- Set RANGE SWITCH to .5V DC.
- Connect the probe lead to the VTVM and connect the common lead to the probe tip.
- Set the probe switch to DC.
- Adjust ZERO control to bring the meter needle exactly to zero at the left side of the scale.
- Remove the connection between the probe tip and the common lead.

**NOTE:** The meter needle will jump when the probe connection is removed from the common lead; this is normal when set in the .5V DC position.

### DC VOLTAGE CALIBRATION

The calibration of all DC voltage scales above .5V is accomplished with the 1.5V DC CAL control.

- Set FUNCTION SWITCH to +DC VOLTS.
- Set RANGE SWITCH to 1.5V.
- Set the probe switch to DC.
- Recheck ZERO adjustment with the input leads connected together.
- Remove the battery from the VTVM and connect the probe tip to the positive end of the battery. Connect the common lead to the negative end of the battery.

- Adjust the 1.5V DC CAL control (through the hole in the side of the cabinet), so the meter needle rests exactly at the red dot to the right of the end of the 1.5 DC scale.

- Reinstall the battery in the VTVM.

NOTE: If a mercury cell is available, you may calibrate the DC voltage ranges by setting the needle to 1.35 volts.

### 0.5 VOLT DC CALIBRATION

The VTVM must be taken out of the cabinet for this adjustment.

- Set FUNCTION SWITCH to +DC VOLTS.

- Set RANGE SWITCH to 1.5V.

NOTE: The accuracy of the 0.5 volt calibration depends on the calibration of the 1.5 volt range. Therefore, 0.5 volt calibration should be done only after the 1.5V DC CAL has been set.

- Set the probe switch to DC.
- Recheck ZERO adjustment with the input leads connected together. **Be sure to perform this step before going on.**
- Connect the probe tip to the center terminal (terminal 2) of R-21, the AC ZERO control, and adjust this control to indicate exactly .5 volts on the 1.5 DC meter scale.
- Leave the probe connected to the center terminal of R-21 and reset the RANGE SWITCH to .5V DC. Now carefully adjust .5V DC CAL (R-29) so the meter needle indicates exactly 5.0 on the meter scale (meter reading is now 0.5 volts).

- Disconnect the probe from terminal 2 of R-21.

IMPORTANT NOTE: Since the AC ZERO calibration control is used for setting up the 0.5 volt calibration, AC ZERO CALIBRATION must always be performed after the 0.5 volt DC range is recalibrated.

- Install the instrument back in the cabinet.

### AC VOLTAGE CALIBRATION

#### AC ZERO CALIBRATION

- Remove the probe lead from the front panel connector.

- Set FUNCTION SWITCH to AC.

- Set RANGE SWITCH to 1.5V.

- Adjust AC ZERO calibration control (through the hole in the side of the cabinet) so the meter needle rests exactly at zero on the left side of the scale.

#### AC CALIBRATION

- Connect the probe lead to the front panel connector.

- Set FUNCTION SWITCH to AC.

- Set RANGE SWITCH to 150V.

- Set the probe switch to AC/OHMS.

CAUTION: You are going to use the AC power line as a voltage source for calibrating the AC voltage scales on your VTVM. Use extreme care as you connect the leads and make the adjustment.

## MAINTENANCE—Continued

### AC CALIBRATION—Continued

- Connect the probe tip and the common lead across the 120 volt AC power line.
- Do not touch the case or the front panel of the VTVM as you make the following adjustment: Adjust AC CAL (through the hole in the side of the cabinet) so the meter needle indicates the exact value of the line voltage (120 volts).

- Disconnect the probe and common lead from the power line.

**NOTE:** If a more accurate source of AC voltage is available, you may use it to calibrate the AC voltage scales.

### OHMS ADJUSTMENT

**NOTE:** The battery must be installed in the VTVM before making this adjustment or taking resistance measurements.

- Set FUNCTION SWITCH to +DC VOLTS.
- Set RANGE SWITCH to 1.5V (RX1).
- Connect the probe tip to the common lead and readjust the front panel ZERO control to set the meter needle at zero.
- Remove the connection between the probe tip and the common lead.
- Now set FUNCTION SWITCH to OHMS.
- Adjust the front panel OHMS control so the meter needle indicates full scale —  $\infty$  on the R scale.
- Touch the probe tip to the common lead; the needle should drop to zero, that is, zero resistance.

### TROUBLE SHOOTING AND MAINTENANCE SUGGESTIONS

Since only highest quality, conservatively rated components are used in this instrument, very little maintenance will be required. However, a few things related to general maintenance should be kept in mind. In order to obtain maximum usefulness and best results, any precision electronic instrument must be handled with care and given proper attention. **Never handle this instrument roughly or carelessly.**

**Static electricity** may build up on the meter face. This accumulation of static electricity will be most noticeable on cold, dry days. The meter needle will become sluggish and sticky in its movement. To remove this static charge, put a small drop of dishwashing detergent on a soft, damp cloth and wipe the meter face with it.

**If you replace a part**, check the calibration of the instrument before using it. If you replace a tube, let the instrument warm up for at least 8 hours before calibration.

**Constant flexing of the test leads** may develop an open circuit in the lead, resulting in erratic meter readings or no reading at all. This problem may show up after a few years of use; always check the continuity of the test leads when this occurs.

**Should you ever suspect the meter movement of being defective**, you can check its continuity with a series resistor and an ohmmeter. Since the current available from an ohmmeter can damage the delicate meter coil, **YOU MUST USE A 1 MEGOHM RESISTOR IN SERIES WITH THE METER IF YOU CHECK THE COIL THIS WAY.**

A smaller resistor may be used only if you know the battery voltage of your ohmmeter and the current available on that resistance range. **CURRENT THROUGH THE METER COIL MUST BE KEPT TO LESS THAN 200 MICROAMPS.**

**CAUTION:** Do not attempt to make any internal adjustments on the meter movement. It is an extremely delicate part and can be damaged easily.

Normal operating voltages have been indicated on the schematic diagram as a maintenance aid. A chart of resistance measurements is given below for your convenience.

| RESISTANCE CHART |         |          |
|------------------|---------|----------|
| Pin              | V-1     | V-2      |
| 1                | 0       | 70K      |
| 2                | 100 Meg | 6.8 Meg  |
| 3                | 0       | 39K      |
| 4                | 1.1     | 0        |
| 5                | inf.    | 0        |
| 6                | n.c.    | 70K      |
| 7                | inf.    | 13.3 Meg |
| 8                | —       | 39K      |
| 9                | —       | 1.1      |

1. Resistance measurements taken from point indicated to chassis with the negative lead of the ohmmeter connected to chassis.
2. RANGE SWITCH set to 1.5V.
3. FUNCTION SWITCH set to +DC.
4. 1.5V DC CAL and OHMS set to approximate center of range.

Additional, detailed troubleshooting hints are listed below to aid you in isolating a problem.

| SYMPTOM  | SERVICE PROCEDURE   |
|--|---|
| Instrument in 1.5V +DC position  |   |
| Filaments of tubes do not light.   | Check transformer T-1.<br>Check line cord.  |
| Filaments light but meter needle does not move.                              | Check V-2 tube.<br>Check voltages on V-2.   |
| Needle deflects but ZERO control has little or no effect on needle movement. | Problem is caused by an open grid circuit in V-2; check resistance from pin 7 and 2 to chassis.<br>Check for open series resistor — R-4 through R-10. |
| Instrument in 1.5V AC position   |   |
| AC ZERO does not control needle movement.                                    | Check V-1 tube.<br>Check resistors R-14, R15, R-16 and R-21.  |
| AC CAL does not control needle movement.                                     | Probe switch in wrong position.<br>Check V-1.   |
| Instrument in OHMS position  |   |
| OHMS control does not affect needle movement.                                | Battery missing or not making contact.<br>Battery in backwards.<br>Replace battery.   |
| Unable to set needle to $\infty$ with OHMS control.                          | Battery weak—replace it.  |



# CIRCUIT DESCRIPTION

## SEE SCHEMATIC DIAGRAM

The operation of your Vacuum Tube Volt Meter centers around a vacuum-tube bridge circuit composed of a dual-triode tube and a high quality meter. The primary advantage of an instrument of this type stems from vacuum-tube operation, because a tube can amplify without taking power from the input signal. Therefore, a VTVM can make sensitive, stable measurements, because it is done electronically.

When the dual-triode bridge is properly balanced, the voltages at the tube plates will be equal. Since the meter is connected between the plates, it will read zero.

R-20, the front panel ZERO control is in the plate circuit of V-2, the dual-triode. This control balances the B+ voltage applied to the two plates of the tube, so that there is no meter indication with no input to the tube.

When a positive voltage is applied to pin 7 grid, current through V-2A increases, resulting in a lowered voltage at the plate of V-2A. Since V-2A current flows through common cathode resistor R-22, the voltage drop across R-22 increases with the increase in V-2A current.

Thus the grid of V-2B is biased more negatively because of the increased voltage drop across the cathode resistor. The current through V-2B will decrease and the voltage at the plate (pin 1) will rise.

Current will flow through the meter due to the difference in potential between the plates. The meter scale is directly calibrated to indicate the magnitude of the voltage applied to the grid of V-2A.

A number of precision resistors are switched in series with the grid of V-2A and so the different ranges are created.

When you use your VTVM to measure AC voltage, the input voltage is first rectified by V-1, a 6AL5 dual diode. This tube functions as a full-wave peak-to-peak rectifier. The operation is as follows:

The positive pulse of an incoming AC voltage will cause V-1A diode to conduct, charging capacitor C-2 to the positive peak of the input voltage. As the AC signal swings in a negative direction, V-1A diode ceases to conduct and the charge on C-2 is retained. The negative peak of the input voltage is added in series with the charge on C-2 and is applied to V-1B diode. V-1B conducts and C-3 charges to a value equal to the sum of the positive and negative peaks.

The charge across C-3 (or a portion of the charge) is applied to the dual-triode bridge-circuit. The meter scale is calibrated in peak-to-peak and RMS values for direct readings.

For resistance measurements, a 1.5 volt battery is connected through a series of precision resistors and the unknown resistance. These two resistances form a voltage dividing network across the battery. The resulting voltage is applied to the bridge circuit and the meter is calibrated in OHMS.

The FUNCTION SWITCH chooses the correct input circuit for the particular use intended. It also switches the correct calibration control into the meter circuit.

The RANGE SWITCH selects the required series resistors for the various ranges of measurements.

AC ZERO screwdriver adjustment compensates for the contact potential developed on the elements of V-1. It is used to set the meter needle to zero for AC voltage readings.

1.5V DC CAL screwdriver adjustment is placed in the meter circuit for all DC voltage ranges above the .5 volt range and is set for a meter reading of exactly 1.5 volts on the 1.5 volt range. This calibration then holds for all DC voltage ranges above that range.

The .5V DC CAL is switched into the meter circuit on the lowest DC range and is used to calibrate this range.

AC CAL is switched into the meter circuit in the AC function position and then is used to calibrate the AC scales with a known input voltage.

Front panel OHMS control sets the meter needle to full scale when the FUNCTION SWITCH is in OHMS position. This control is switched into the meter circuit in the OHMS function.

The AC/OHMS DC switch on the probe, switches a 1 Megohm resistor in series with the input circuit when in the DC position. This resistor acts as an isolation resistor for DC voltage measurements. In the AC/OHMS position, this resistor is shorted out of the input circuit.

Since all input voltages are applied to the tube circuit rather than the meter, the meter is automatically protected from overload or burnout. The maximum conduction capability of the 12AU7 tube limits the meter current drain to a safe value.

You will notice one important feature from the schematic. In the OFF position of the FUNCTION SWITCH, a short circuit is placed across the meter terminals by the rear section of S-1A. This provides meter damping and protection during transit.

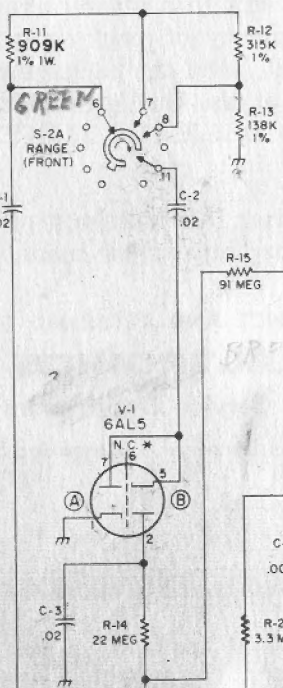
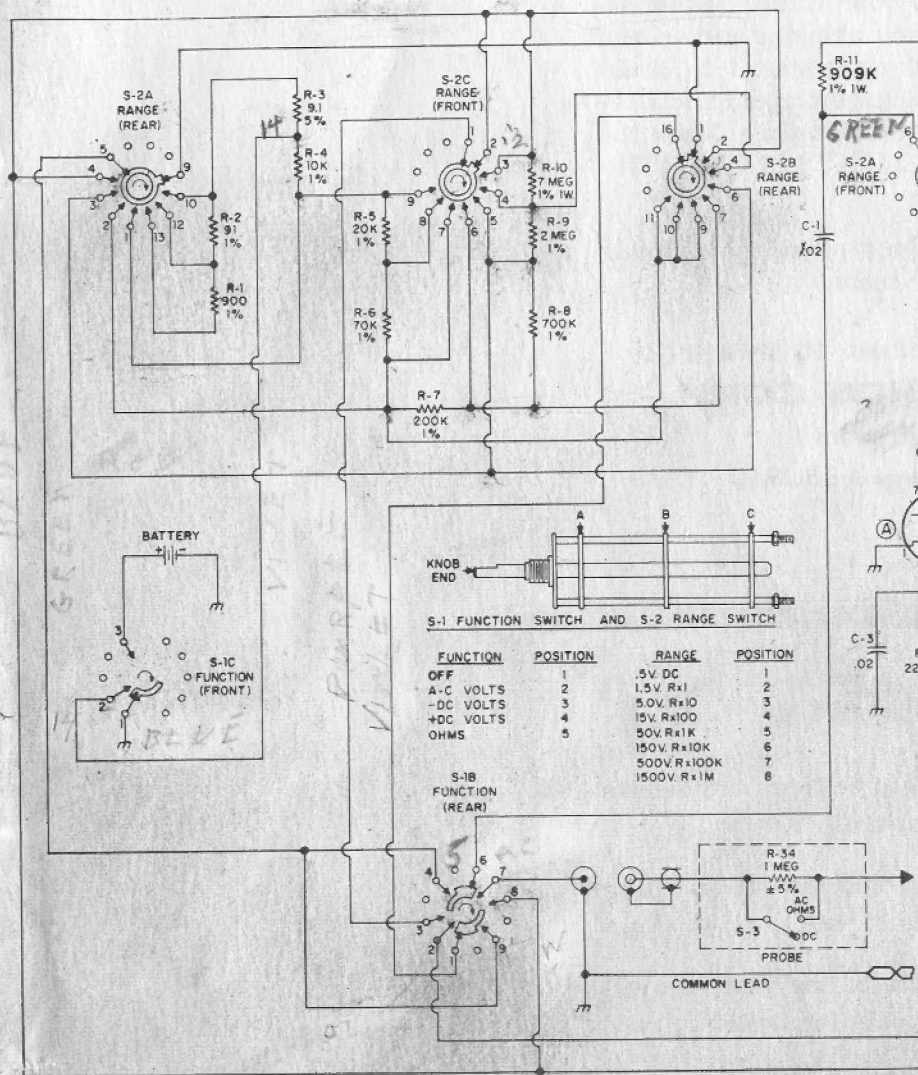

**NOTES**

CAPACITORS INDICATED IN MICROFARADS.  
RESISTORS INDICATED IN OHMS.  
K = 1,000 OHMS.  
MEG = 1,000,000 OHMS.

SWITCHES (S-1) AND (S-2) ARE SHOWN IN MAXIMUM COUNTER-CLOCKWISE POSITION (POSITION 1) AS VIEWED FROM FRONT OR KNOB END.

⊥ = CHASSIS GROUND.  
\* = INTERNAL SHIELD - NO CONNECTION.

**VOLTAGE MEASUREMENTS**

VOLTAGE MEASUREMENTS ARE MADE FROM POINTS INDICATED TO CHASSIS GROUND USING A 20KΩ/V DC METER & A 5KΩ/V AC METER.

FUNCTION SWITCH (S-1) IN +DC VOLTS, POSITION 4.  
RANGE SWITCH (S-2) IN 1.5V R x 1, POSITION 2.  
ZERO (R-20) IN APPROXIMATE CENTER OF RANGE.  
TEST LEADS DISCONNECTED.  
LINE VOLTAGE: 120 VOLTS 60 CYCLES AC.  
VOLTAGE TOLERANCE ± 20%.

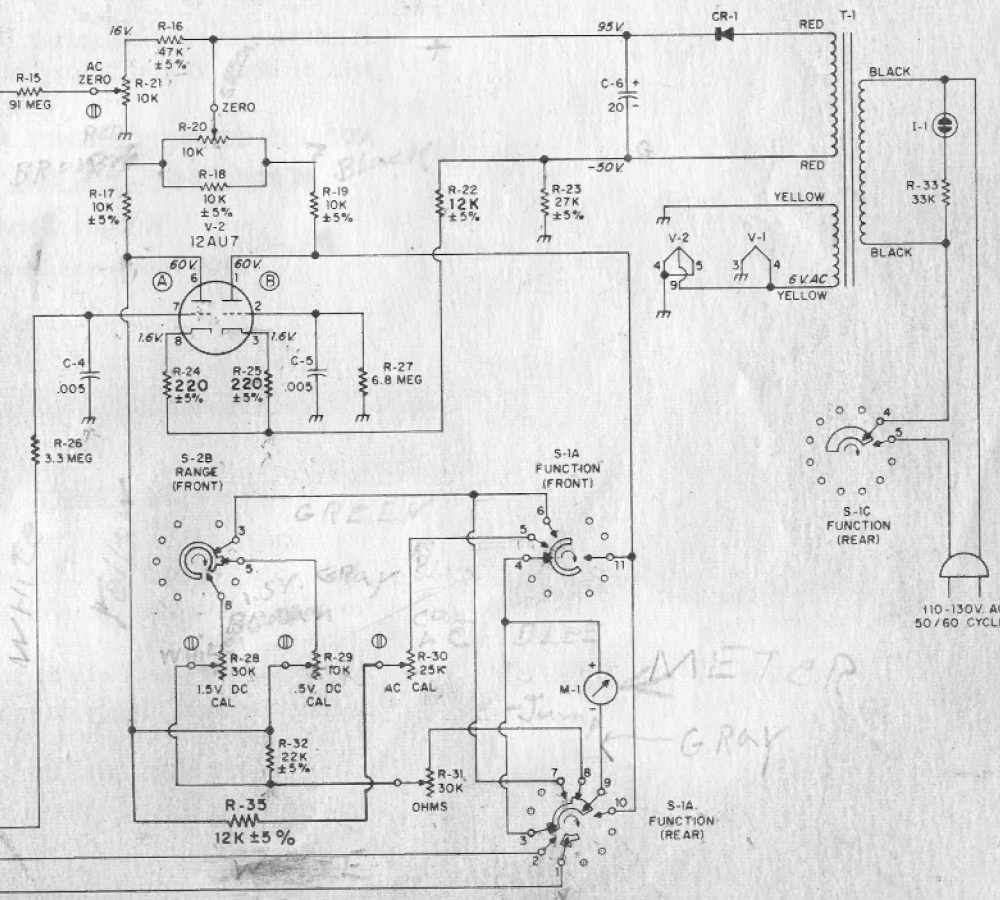

**SCHEMATIC DIAGRAM**